

CURB INSTALLATION INSTRUCTIONS

FOR **NEW CONCEPT LOUVERS'** READY-MADE ALUMINUM CUPOLAS

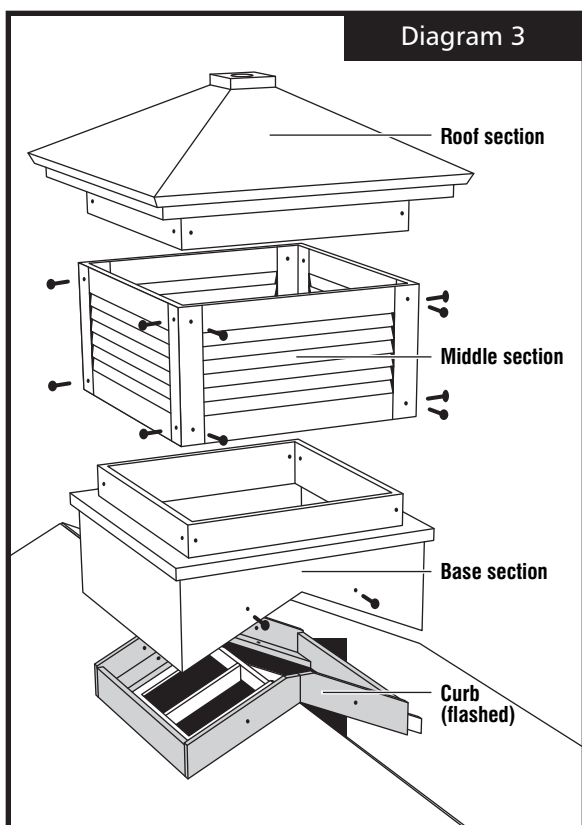
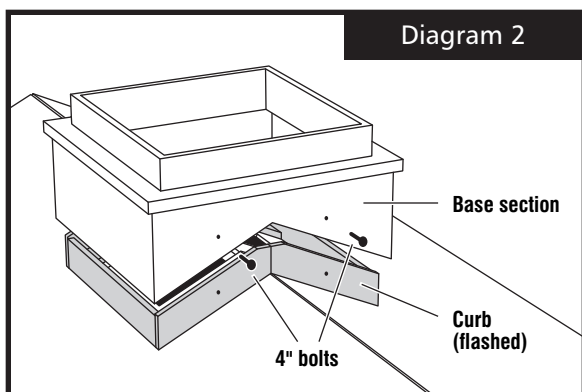
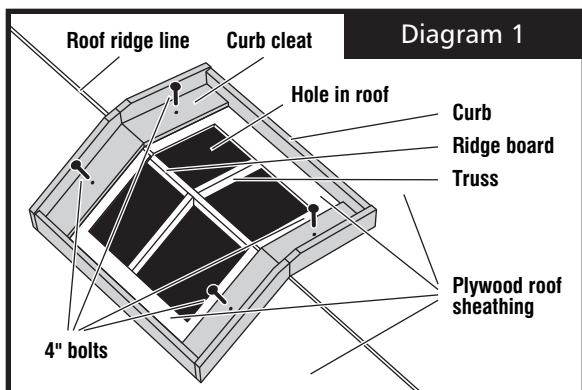

The curb is generally used to attach the ready-made cupola to the roof of new construction. (For attachment to an existing roof, the standard built-in cleats in the base section of the cupola will usually do the job.)

1. If the cupola will be used for venting, set the curb in place on the roof and mark where the hole is to be cut in the roof sheathing, coming in a few inches from the inside of the curb all around. Set the curb aside and use a circular saw to cut the hole in the sheathing. Set the cutting depth just enough to go through the plywood sheathing ($\frac{5}{8}$ " to $\frac{3}{4}$ "). Do not cut through the 2 x 4 ridge board or any trusses. If a truss is exposed by removal of the sheathing, that's okay. (See Diagram 1.)
2. Set the curb back in place over the hole and bolt it to the roof sheathing using the four 4" bolts provided. One bolt should be used at the center of each of the curb's four 2 x 8 cleats that rest flat against the pitch of the roof. (See Diagram 1.)
3. Flash around the entire outside of the curb as tightly as possible. We have allowed $\frac{1}{4}$ " clearance on each side of the curb for flashing.
4. If waiting for the cupola to be delivered, cover the opening of the curb with wood or Visqueen to keep rain out.
5. Using the four 4" painted carriage bolts provided, bolt the base section of the cupola to the sides of the curb that rise with the roof pitch, at the spots indicated in Diagram 2. To assure watertightness, squeeze caulk into the holes in the base section before inserting the bolts. Shim where the bolts attach for a snug fit.
6. Attach the middle and roof sections of the cupola according to the instructions in Step 5 of the standard installation instructions that ship with the cupola, replacing the $\frac{1}{2}$ " stainless-steel screws at the corners of the middle section with the provided 2" painted stainless-steel screws that are designed to attach the middle section to the base and roof sections. (See Diagram 3.)

If you have any questions, please call us at **800-675-6555**.



www.LarsonShutter.com
1.800.675.6555